

## INSTALLATION GUIDE

LATEST UPDATE: AUGUST 25, 2010, By MIKKEL HARTVIG ANDERSEN

PAGE 1

TOTAL OF 14

H1

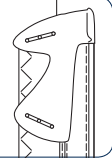

ALL RIGHTS RESERVED. FOILFEED® IS A PROPRIETARY AND REGISTERED TRADEMARK OF SIRIUZ APS. PATENTED

HEADSAILS

# 5 minutes and your feeding will never be the same again...

## About this guide

Use this guide when installing the H1 to your luff tapes. The guide is based on the basic geometrical principles and dimensions of the Foilfeed® H1 and the experiences derived from installment by various sailmakers around the world. The guide will continually be updated.

## Share your installment experiences

If you do have additions to this guide, or any general comments about the product, we will happily accept these and mail them to [comments@foilfeed.com](mailto:comments@foilfeed.com).

## Advantages gained by installing Foilfeed® H1

- Protects LuffTapes when inserted and functioning in grooves
- 100% hoisting and feeding reliability
- Quality improvement compared to all existing sailmaking standards
- Mounting by simple stitching. No permanent damage to sail
- Save time and money mounting Foilfeed® to your customers sails
- No ease-out solutions needed
- Easier, safer and faster handling for bowmen
- H1 come in 1 size: For 6 mm rope (single and double)
- Made in white Nylon®. UV-block added

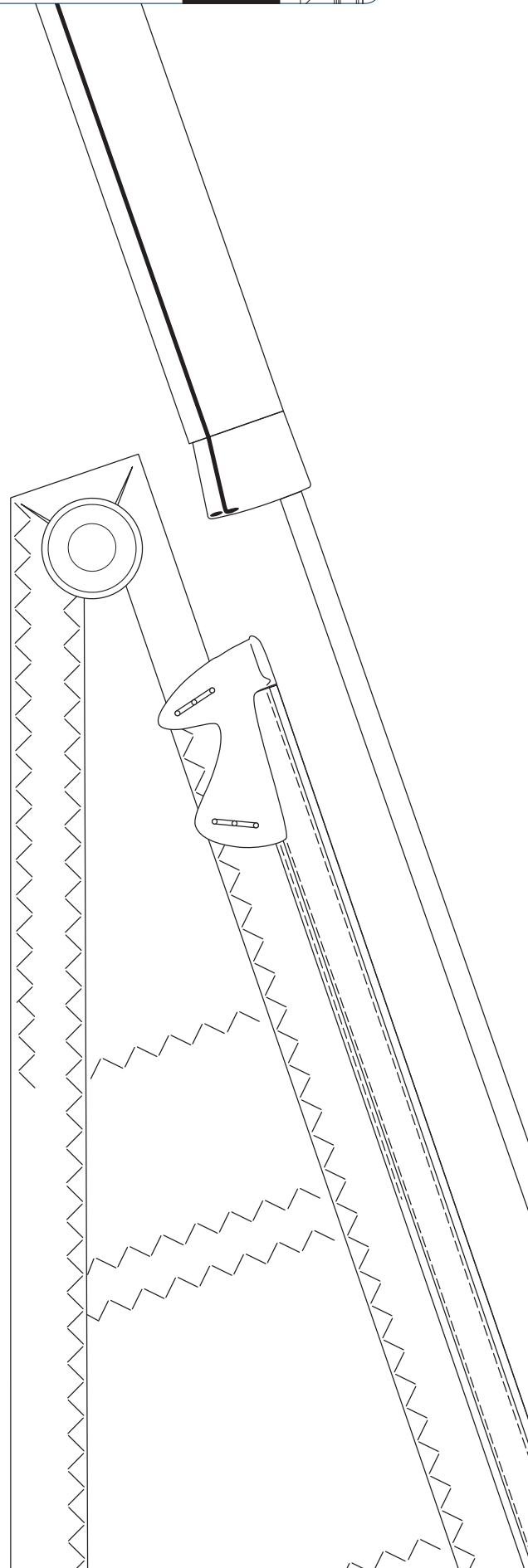

## INSTALLATION GUIDE

LATEST UPDATE: AUGUST 25, 2010, By MIKKEL HARTVIG ANDERSEN

PAGE 2

TOTAL OF 14

H1

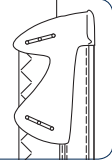

HEADSAILS

## About the Luff Tapes

Foilfeed® H1 can be used on both single- and double roped tapes and is designed specifically for a **6 mm** rope diameter. Tests have proven that diameters 5- and 7 mm works too on most setups, although it has to be determined by the individual setup of foil dimensions, brackets and other fixtures involved in the feeding. Just sow the tape onto the headsail without ease-out or any other protective arrangements.

Attention:

If you have a sail with ease-out at the end, either rip up the stitches on the tape and sow back to proper position or cut the luff tape just below the point where the ease-out starts.

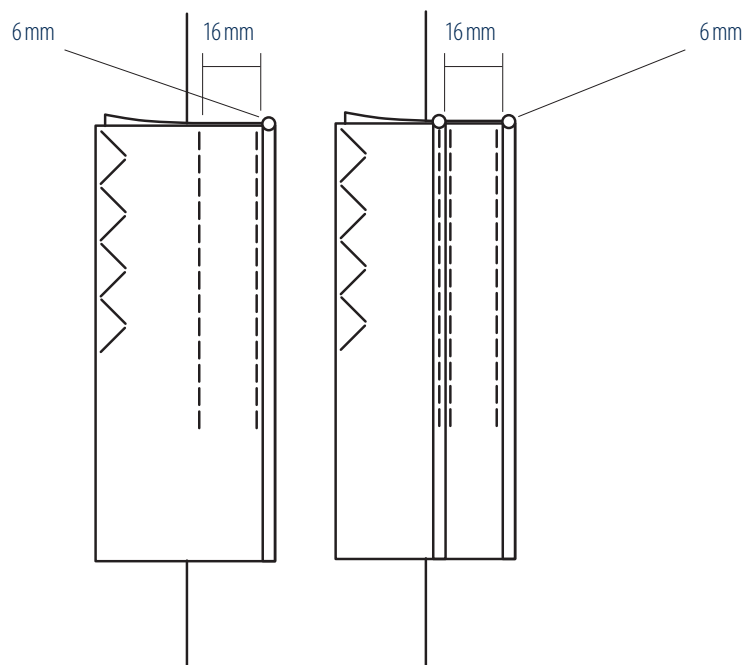

# INSTALLATION GUIDE

LATEST UPDATE: AUGUST 25, 2010, By MIKKEL HARTVIG ANDERSEN

PAGE 3

TOTAL OF 14

# H1

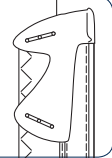

HEADSAILS

ALL RIGHTS RESERVED. FOILFEED® IS A PROPRIETARY AND REGISTERED TRADEMARK OF SIRIUZ APS. **PATENTED**

## Geometry and design

The Foilfeed® H1 is designed to meet the geometrical requirements of all major suppliers of headsail furlings systems, foil extrusions and grooves, including feeders. Though the H1 is primarily made for 6 mm ropes, it has also proven usable on 5 mm and 7 mm ropes too, though it depends entirely on the actual setup.

The 'projectile' (item advanced into groove) is designed to be inserted both forth and back, meaning that a fully hoisted sail on too short an extrusion, will be able to feed back when lowering the sail again.

The Spike (pin lowered into the rope) cannot break by either stepping on or by normal handling. It will only bend sideways. Since it is 25 mm long it will not be able to 'jump' out of position unless the whole area is being ripped apart.

Attaching Foilfeed® H1 to the sail is done by hand stitching. When tightening and securing the thread, the stitching will be lowered into the built-in grooves protecting it from tear and wear of general sail handling.

The Foilfeed® H1 weighs 19 grams.

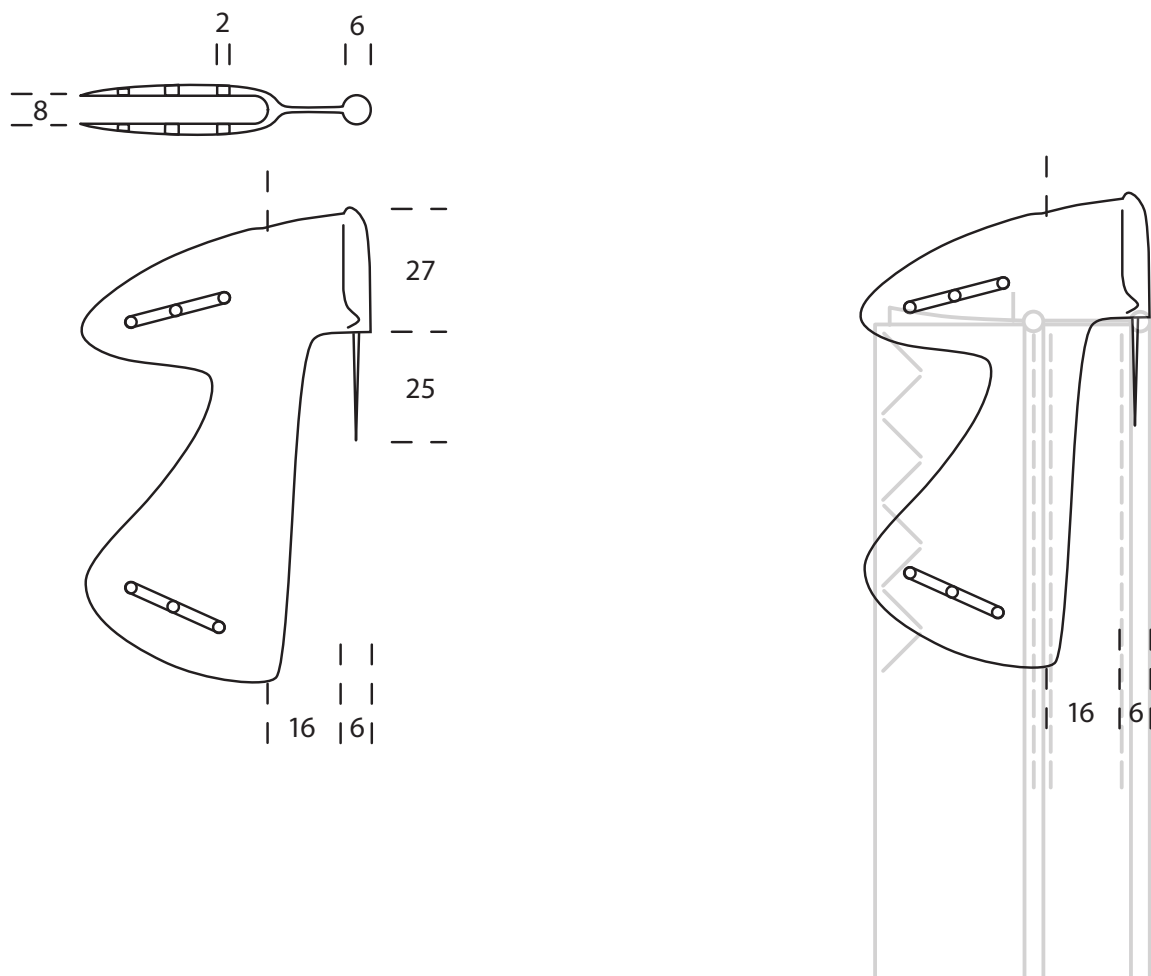

## INSTALLATION GUIDE

LATEST UPDATE: AUGUST 25, 2010, By MIKKEL HARTVIG ANDERSEN

PAGE 4

TOTAL OF 14

H1

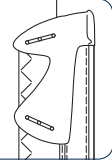

HEADSAILS

## Warning: Avoid ease-out solutions

Some sailmaking brands has made it a standard of finishing the luff tape ends with an eased outward bent keder, that automatically releases the tension between the groove and the sail. That is a simple way of trying to avoid the immediate chafe and fray problems of the luff tape end, but only to a certain extent.

The Foilfeed® H1 is designed to meet the geometrical requirements of a normally fixed luff tape, all the way up along the designed luff curve. This has the advantage of controlling the designed luff curve almost all way up to the top of the sail. With ease-out solutions, the last point of fixation of the designed luff curve starts about a foot (about 35 cm) lower which compromises the shape control.

**See the more detailed explanation** of the ease-out problems on the pages 12 and 13 of this installation guide.

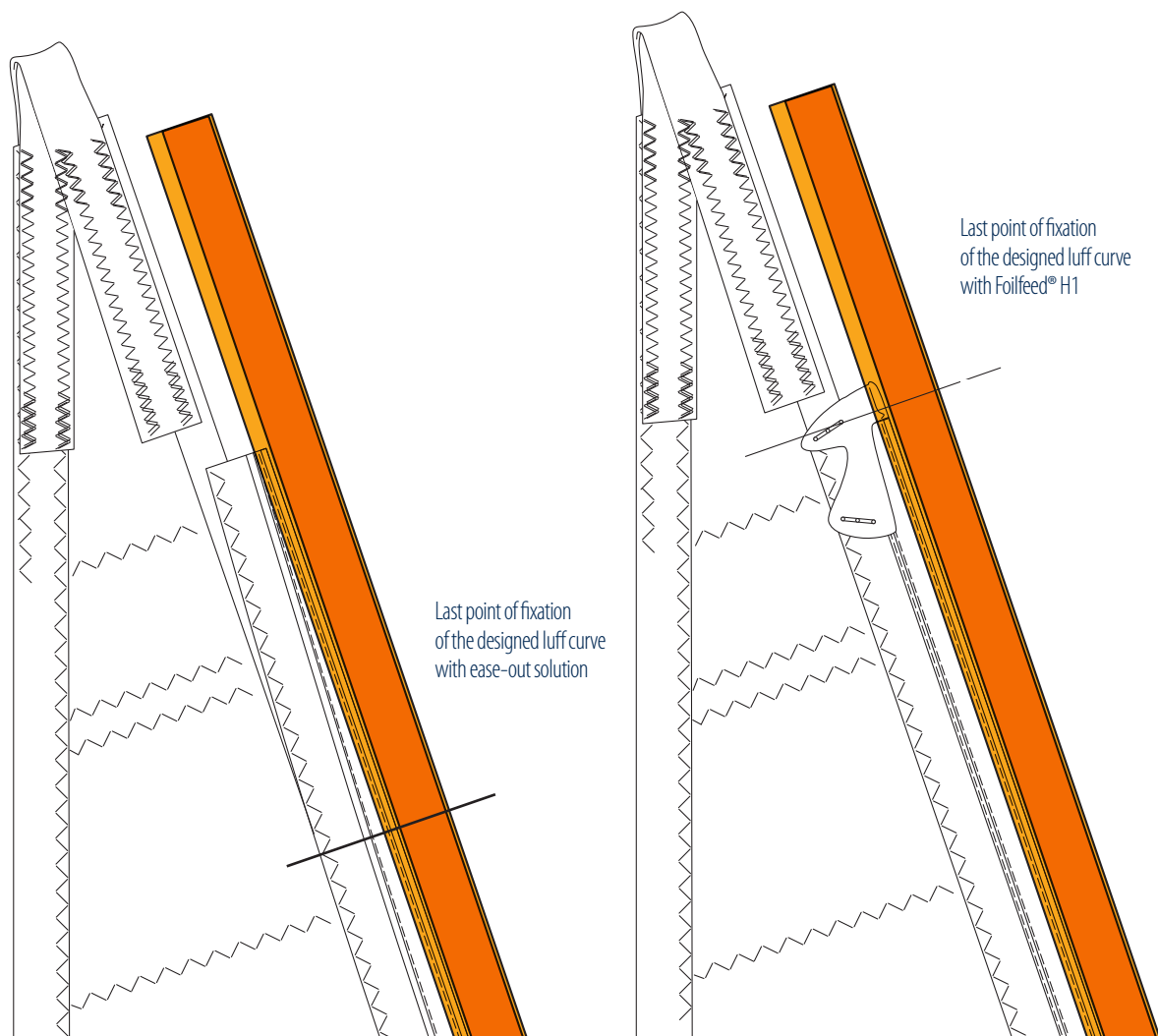

## INSTALLATION GUIDE

LATEST UPDATE: AUGUST 25, 2010, By MIKKEL HARTVIG ANDERSEN

PAGE 5

TOTAL OF 14

H1

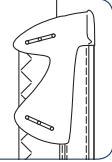

ALL RIGHTS RESERVED. FOILFEED® IS A PROPRIETARY AND REGISTERED TRADEMARK OF SIRIUZ APS. PATENTED

HEADSAILS

# Step 1

## 1. Any tape solution; Avoid Ease-out solutions

Foilfeed® H1 can be used on both single- and double bolt roped tapes and is designed specifically for a 6 mm rope diameter. Tests have proven that diameters 5- and 7 mm works too on most setups, though it has to be determined by the individual setup. Just sow the tape onto the headsail without ease-out or any other protective arrangements.

Attention:

If you have a sail with ease-out at the end, either rip up the stitches on the tape and sow, following the designed luff curve.

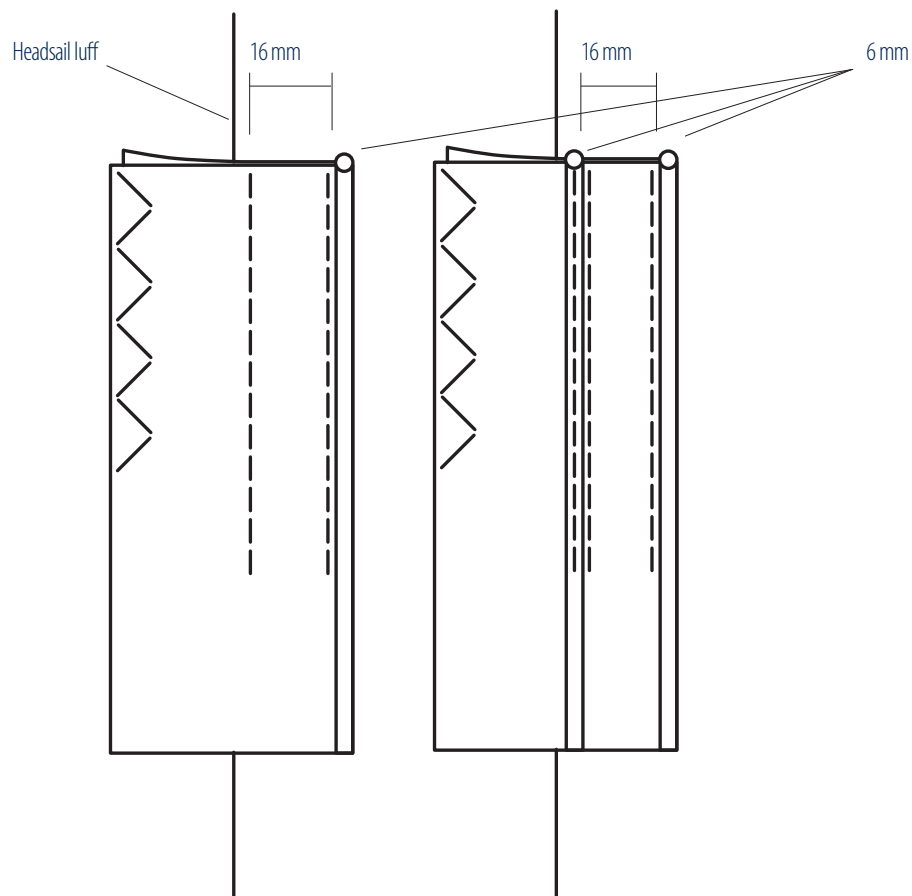

## INSTALLATION GUIDE

LATEST UPDATE: AUGUST 25, 2010, By MIKKEL HARTVIG ANDERSEN

PAGE 6

TOTAL OF 14

H1

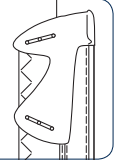

ALL RIGHTS RESERVED. FOILFEED® IS A PROPRIETARY AND REGISTERED TRADEMARK OF SIRIUZ APS. PATENTED

HEADSAILS

## Step 2

### 2. Drill down a cavity for the pin in the center of the dense bolt rope

The spike of the Foilfeed® H1 is designed to align the bolt rope with the H1. Getting it down 20 mm without bending the spike is almost impossible without compromising the installation. Therefore use a highspeed drill to create a cavity, so that the spike can slide down firmly without any hazzle at all. The keyword is friction; It creates heat that melts the cavity.

Burn the edges of both the luff tape and the bolt rope.

Attention:

You can mount a sailmaking needle to the drill. Experience shows that it creates the necessary heat. This is not about removing material, but merely melting your way down the bolt rope, creating space for the spike.

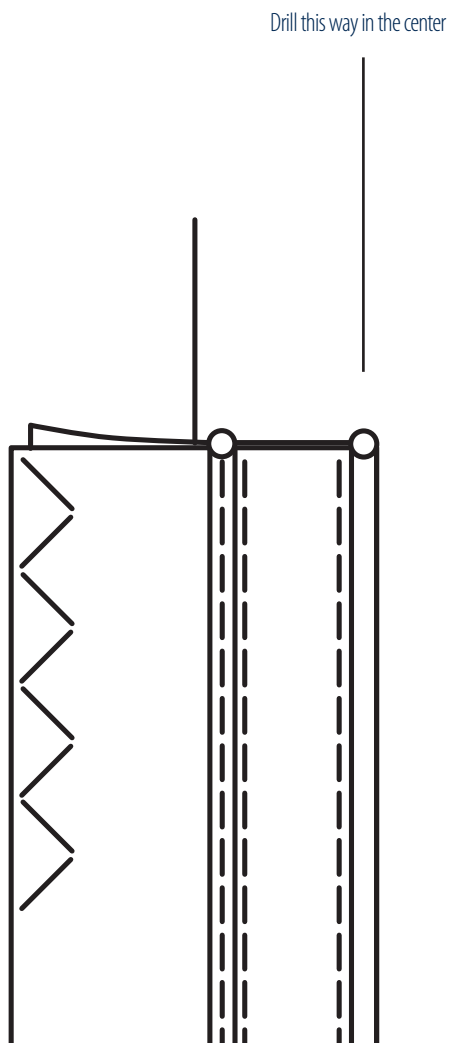

## INSTALLATION GUIDE

LATEST UPDATE: AUGUST 25, 2010, By MIKKEL HARTVIG ANDERSEN

PAGE 7

TOTAL OF 14

H1

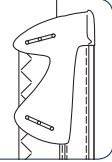

HEADSAILS

# Step 3

## 3. Slide tape from bottom up into the Foilfeed® H1

Mount the Foilfeed® H1 gently onto the luff tape from the bottom. The luff tape shall slide in between the foilfeeds center slit.

Attention:

Make sure that the two tapes holding the rope have NO other material between them, than the tapes themselves. Spinnaker tape, stitches or resin leftovers leads to larger volumes and dimensions and the H1 will not close the luff tape edge properly. Either cut the tape down to a clean part or make a complete clean-up.

Shown from the top



Shown from starboard side

Fold on each side of luff tape and sail

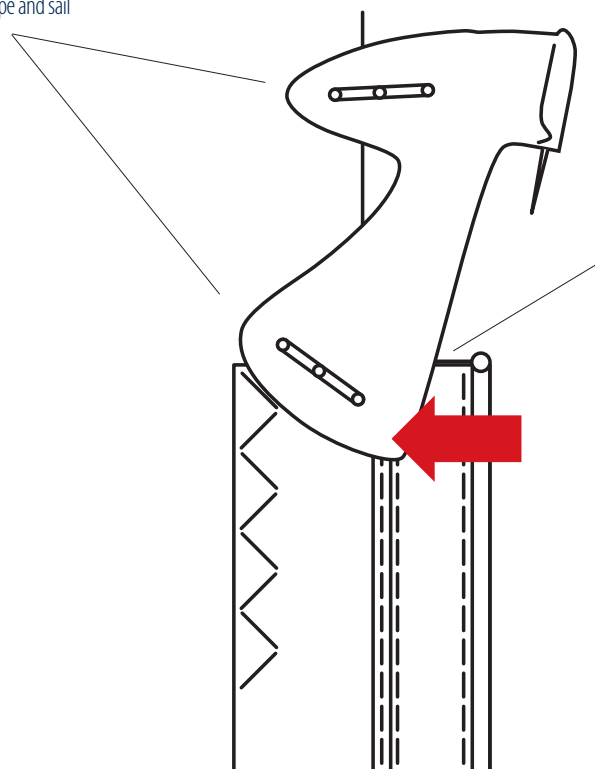

Soft middle part of the tape goes in between the slit of the Foilfeed® H1, but in front of the extra bolt rope.

## INSTALLATION GUIDE

LATEST UPDATE: AUGUST 25, 2010, By MIKKEL HARTVIG ANDERSEN

PAGE 8

TOTAL OF 14

H1

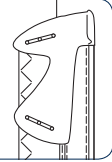

ALL RIGHTS RESERVED. FOILFEED® IS A PROPRIETARY AND REGISTERED TRADEMARK OF SIRIUZ APS. PATENTED

HEADSAILS

# Step 4

## 4. Slide Foilfeed® H1 firmly down

Press the Foilfeed® H1 firmly with its back onto to the sail side of the luff tape so that it is fully supported top to down on the inside. Align the outer rope and the 'projectile' with the 'Spike' pointing down the center of the ropes drilled cavity.

Let the inner edge of the Foilfeed® H1 slide down along the edge of the inner boltrope.

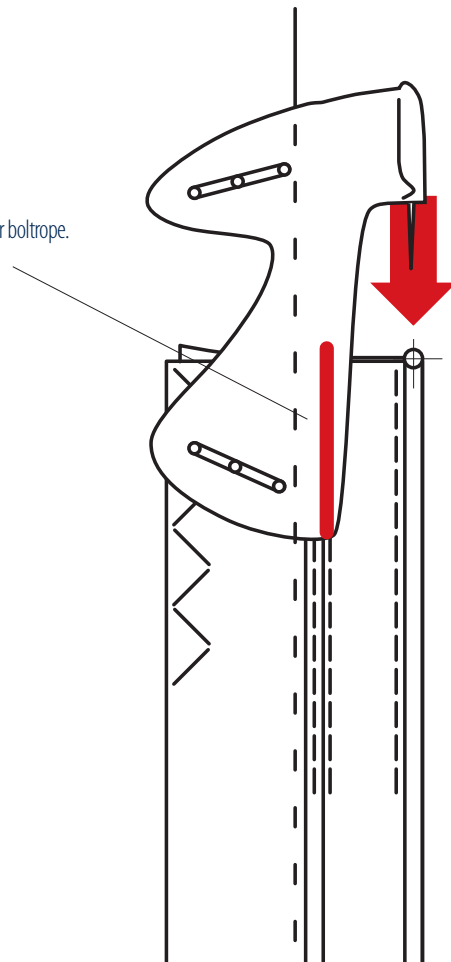

## INSTALLATION GUIDE

LATEST UPDATE: AUGUST 25, 2010, By MIKKEL HARTVIG ANDERSEN

PAGE 9

TOTAL OF 14

H1

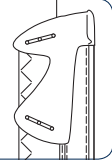

ALL RIGHTS RESERVED. FOILFEED® IS A PROPRIETARY AND REGISTERED TRADEMARK OF SIRIUZ APS. PATENTED

HEADSAILS

# Step 5

## 5. Lower spike firmly into rope

Slide the Foilfeed® H1 down firmly and position precisely, so the spike is completely lowered into the center of the rope. The gap between the 'Projectile' and bolt rope shall close completely. The luff tape edge shall be hidden inside the Foilfeed® H1's slit. No open gaps allowed. Make sure that the fastening/ stitching helps tightening this position.

The Foilfeed® H1 completely cover the whole end of the luff tape.

The middle part of the tape shall be covered all way up in the slit.

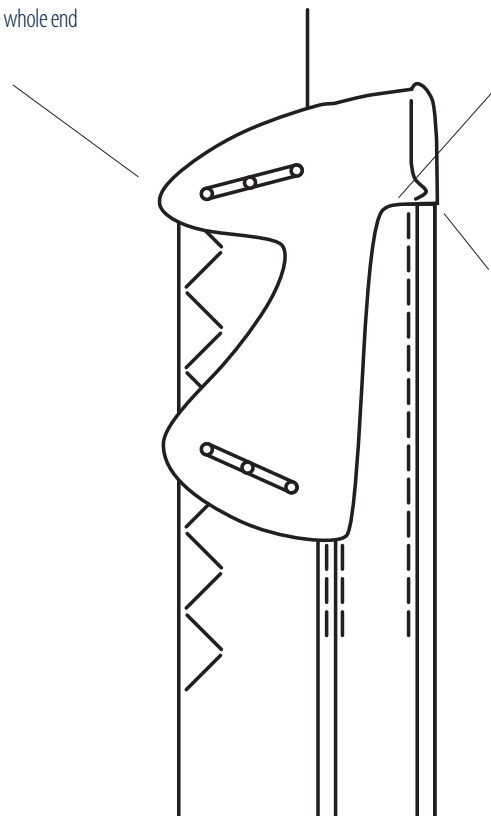

Make sure the gap is completely closed between the end of the 'projectile' and the top of the bolt rope

## INSTALLATION GUIDE

LATEST UPDATE: AUGUST 25, 2010, By MIKKEL HARTVIG ANDERSEN

PAGE 10

TOTAL OF 14

H1

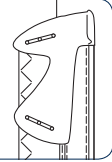

ALL RIGHTS RESERVED. FOILFEED® IS A PROPRIETARY AND REGISTERED TRADEMARK OF SIRIUZ APS. PATENTED

HEADSAILS

# Step 6

## 6. Stitch, finish and fly...

Stitch - with a sailmakers needle and waxed thread - both ends of the Foilfeed® H1 in order to lock the position firmly to the sail. Make sure your stitching is tight in order to stabilize the fixture. Your feeding will never be the same again...

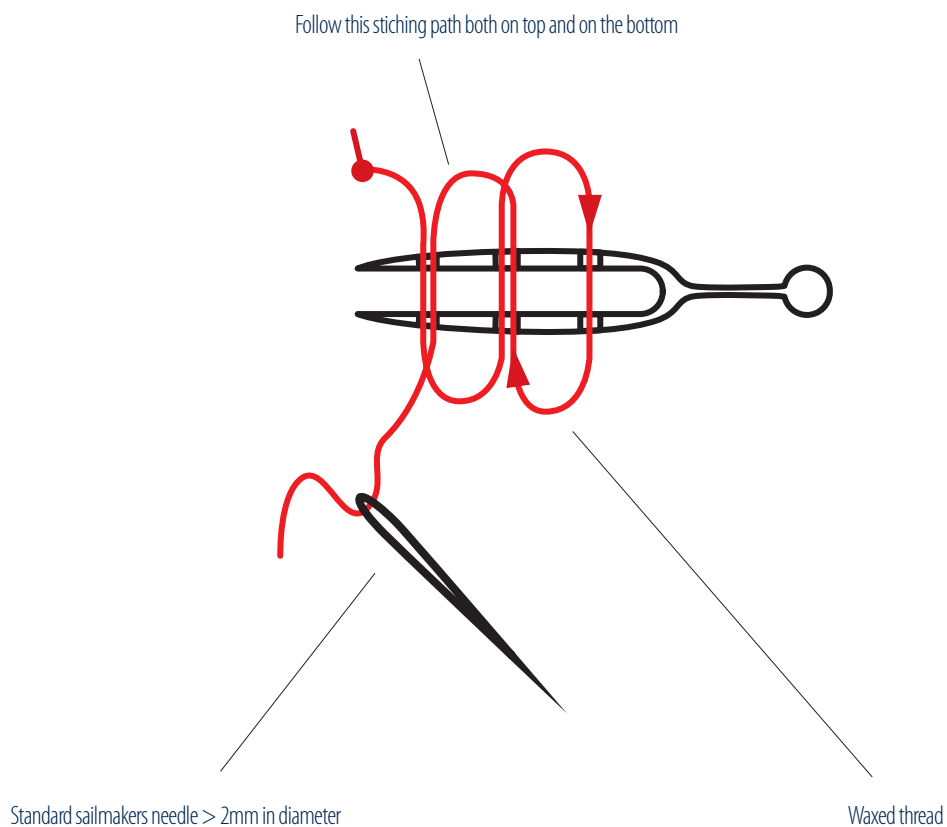

# INSTALLATION GUIDE

LATEST UPDATE: AUGUST 25, 2010, By MIKKEL HARTVIG ANDERSEN

PAGE 11

TOTAL OF 14

# H1

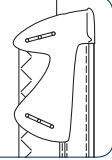

ALL RIGHTS RESERVED. FOILFEED® IS A PROPRIETARY AND REGISTERED TRADEMARK OF SIRIUZ APS. **PATENTED**

HEADSAILS

## Example with web fixture for halyard

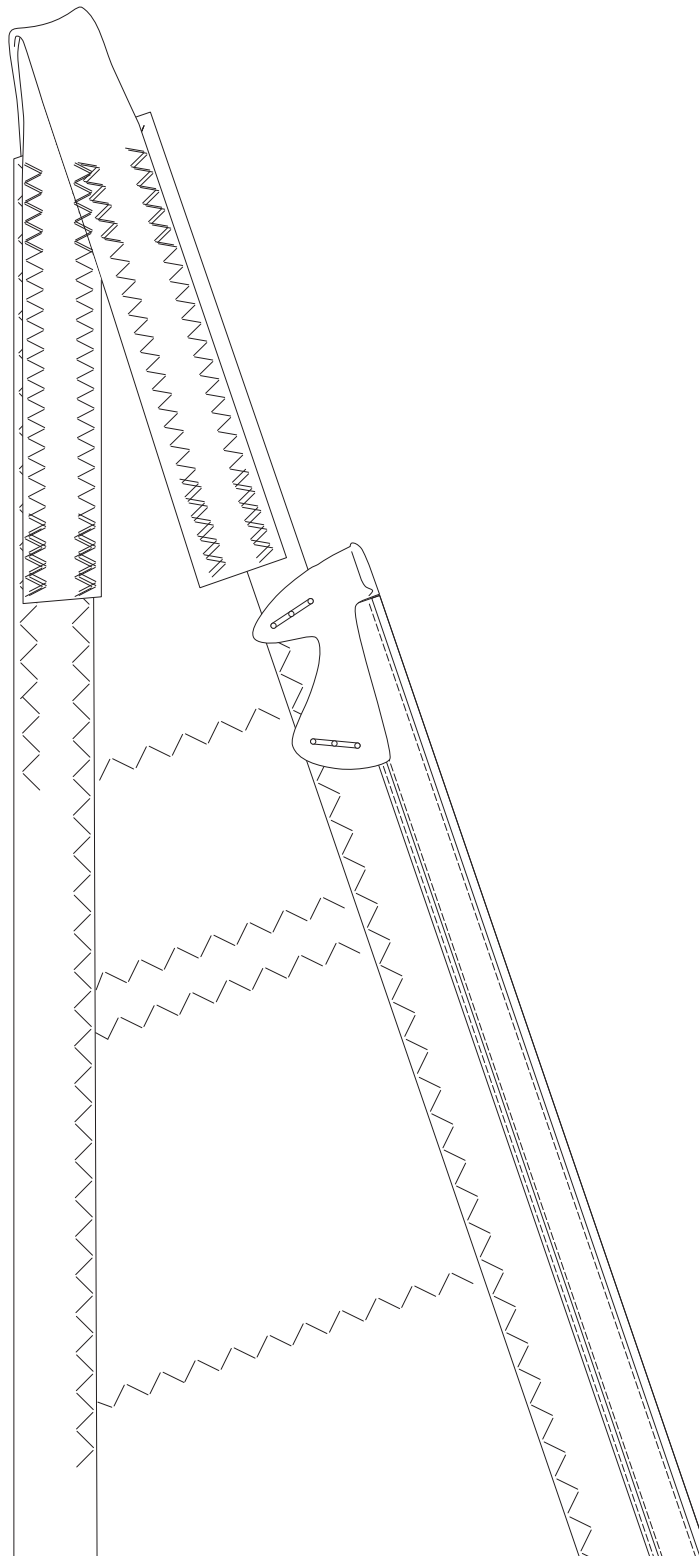

# INSTALLATION GUIDE

LATEST UPDATE: AUGUST 25, 2010, By MIKKEL HARTVIG ANDERSEN

PAGE 12

TOTAL OF 14

# H1

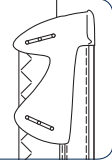

ALL RIGHTS RESERVED. FOILFEED® IS A PROPRIETARY AND REGISTERED TRADEMARK OF SIRIUZ APS. **PATENTED**

HEADSAILS

## Example with liner fixture for halyard

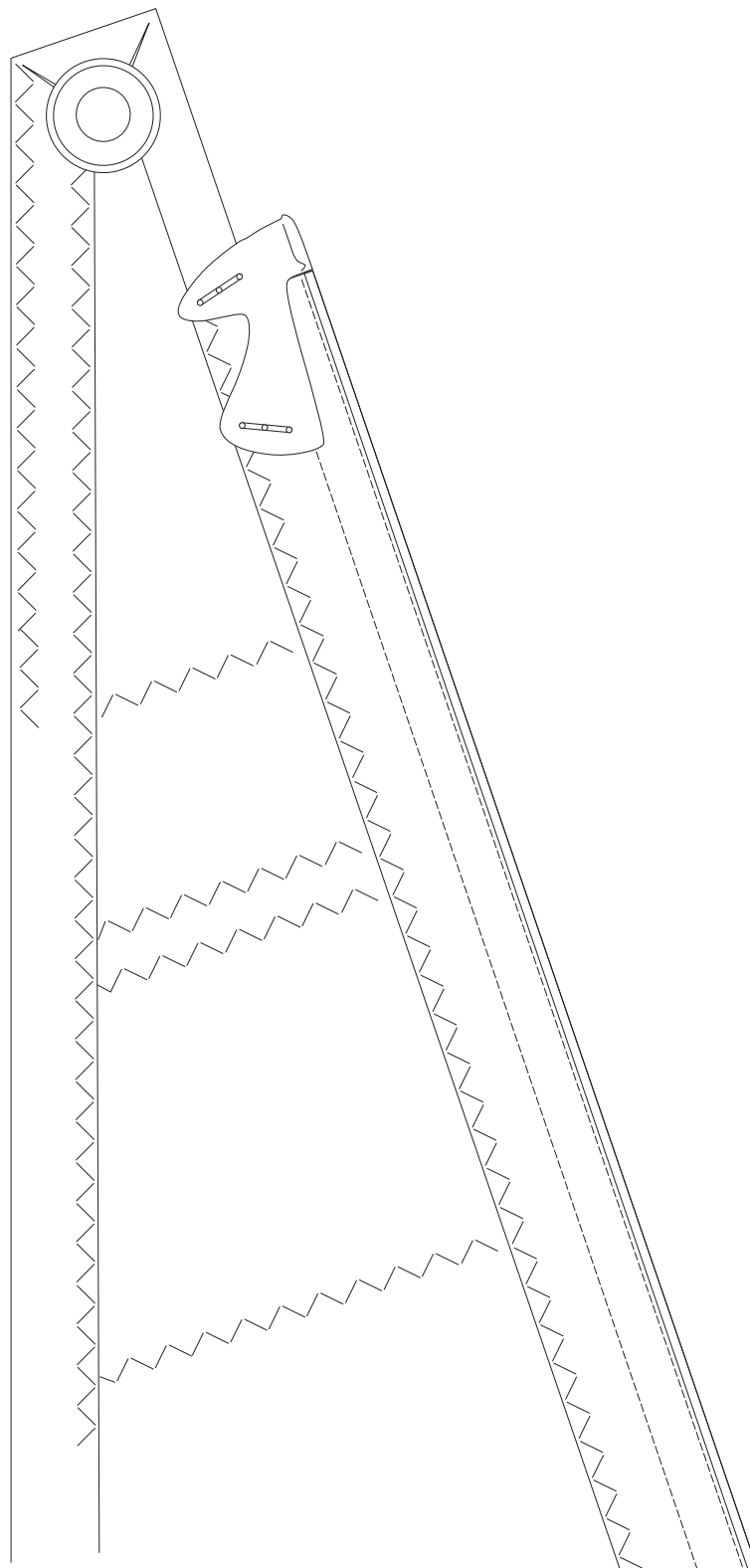

## INSTALLATION GUIDE

LATEST UPDATE: AUGUST 25, 2010, By MIKKEL HARTVIG ANDERSEN

PAGE 13

TOTAL OF 14

H1

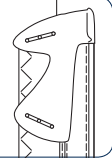

HEADSAILS

# Warning: Avoid ease-out solutions

Since the Foilfeed® H1 is a hard shell, it will fixate the upper position of the head. With ease-out solutions the tape will disorient the fix point of the head in regard to the luff curve and the design will be lost in deformed alignments of the luff tape. Complications are:

- Loss of intended design
- New sheeting angles
- Deformed luff curve
- Uneven stress loads of foil, tape and sail

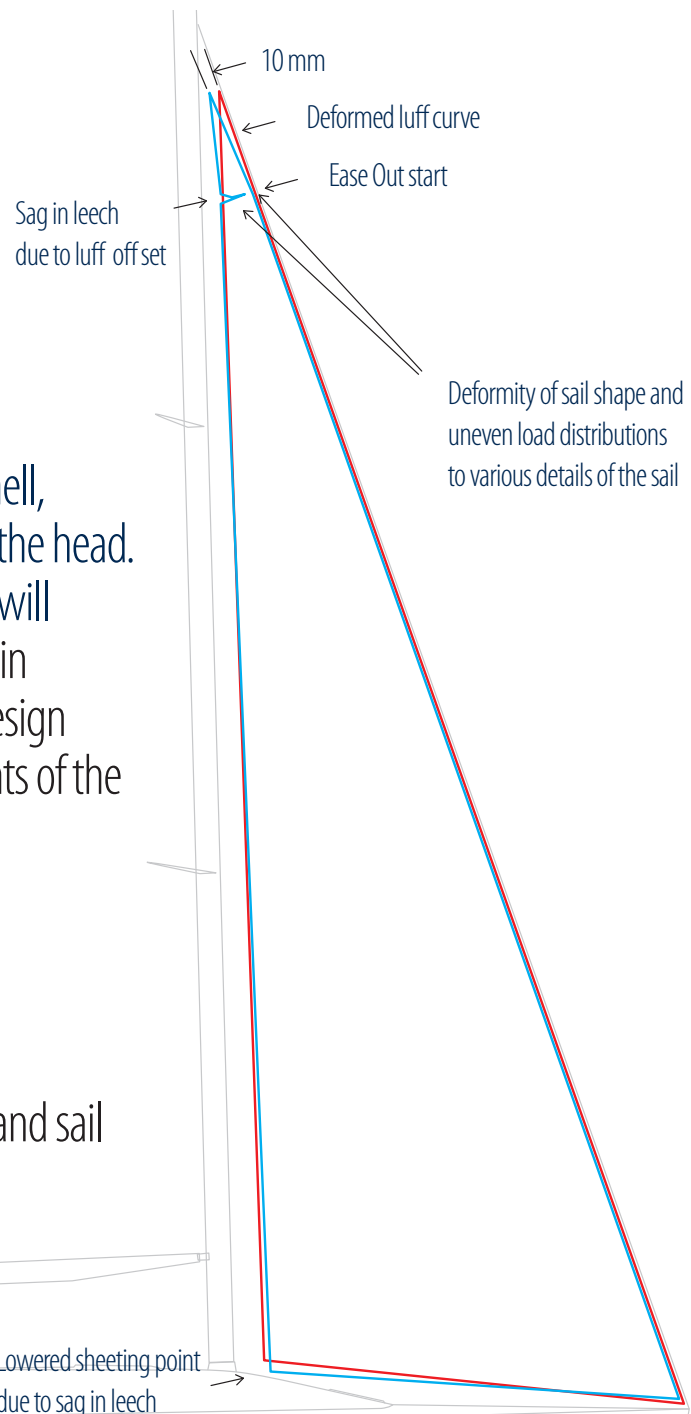

# INSTALLATION GUIDE

LATEST UPDATE: AUGUST 25, 2010, By MIKKEL HARTVIG ANDERSEN

PAGE 14

TOTAL OF 14

ALL RIGHTS RESERVED. FOILFEED® IS A PROPRIETARY AND REGISTERED TRADEMARK OF SIRIUZ APS. **PATENTED**

# H1

HEADSAILS

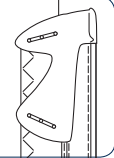

## Warning: Avoid ease-out solutions

